

REVISIONS					
NO.	DATE	ECN #	REMARKS	BY	APPD.

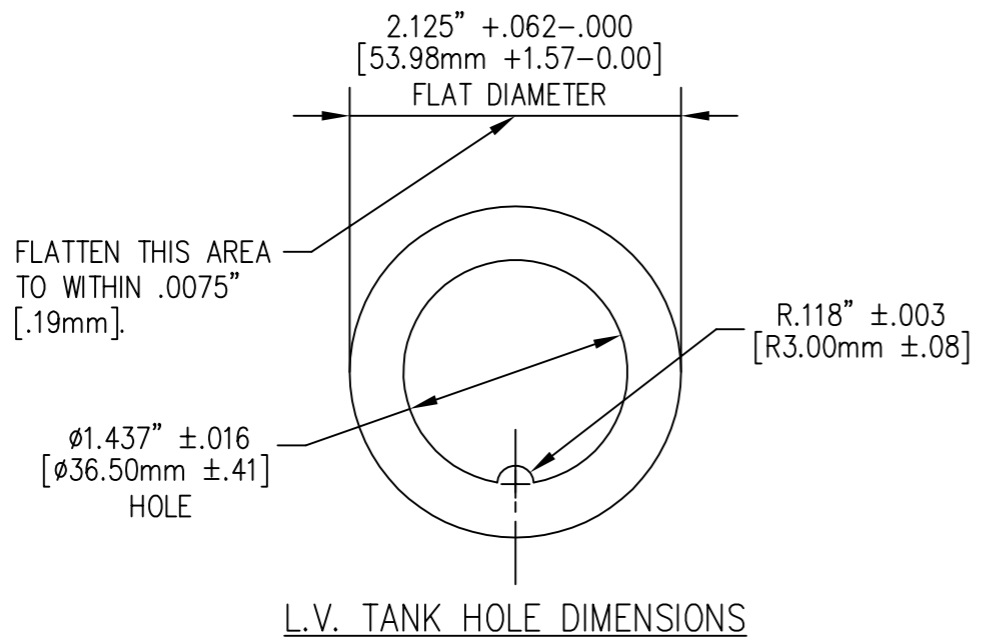
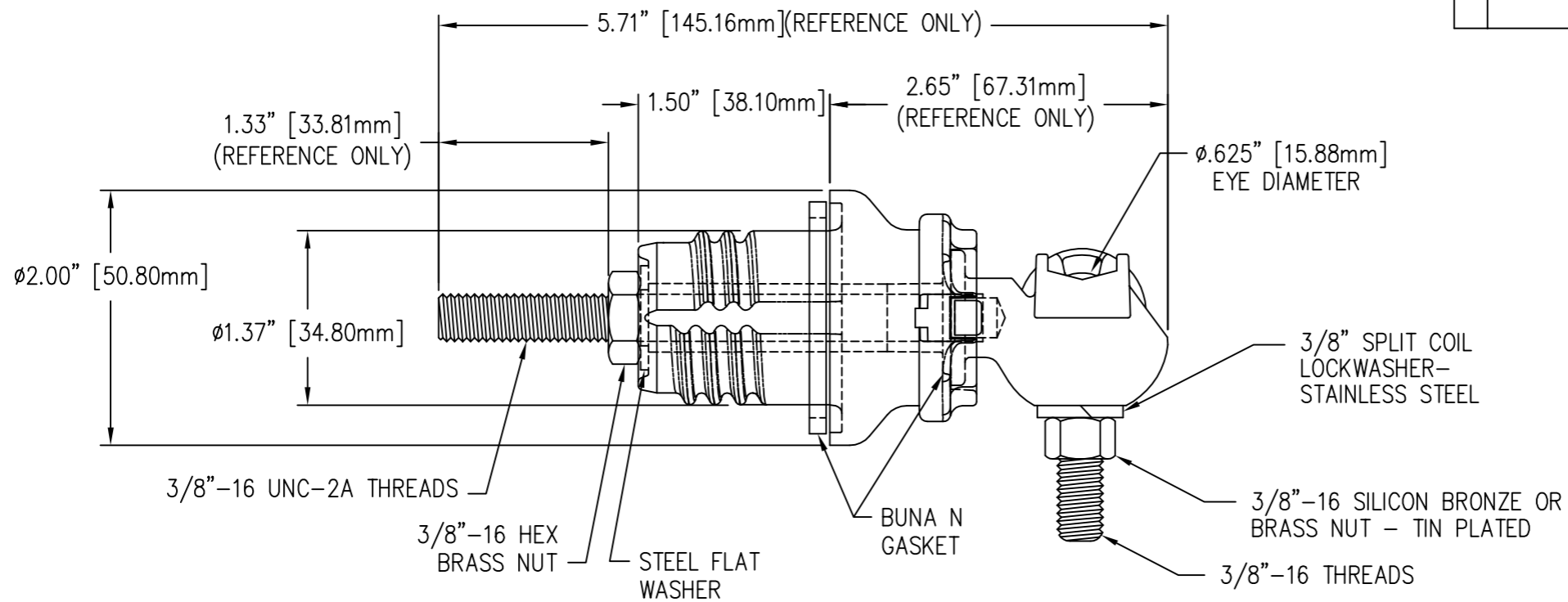

MATERIAL:
 STUD - COPPER CDA 11000
 BODY - CDA 84400 TIN PLATED
 EYEBOLT - CDA 95500 TIN PLATED

TOLERANCES (EXCEPT AS NOTED) DECIMAL $\pm .032" / .8mm$ FRACTIONAL \pm ANGULAR $\pm 2^\circ$		H-J ENTERPRISES, INC. 3010 HIGH RIDGE BLVD. HIGH RIDGE, MO. 63049 USA PHONE 1-636-677-3421 FAX 1-636-376-1915		
		15 KVA L.V. BUSHING ASSEMBLY NON-PORCELAIN INSULATOR		
		MATERIAL (SEE ABOVE)		
		CHK'D	APP'D	DRAWING NO.
DRAWN BY CJT	DATE 7-21-08	SCALE N.T.S.	AS1581-001	